

Model: LXSG-15E-50E

Multi Jet Water Meter

Feature:

- Multi jet, Dry-dial
- Material body: Gray cast iron / Ductile cast iron
- Size: DN15 to DN50mm, (1/2" – 2")
- Available for cold water (50°C), hot water (90°C)
- Accuracy: Class B / Class C



Main Technical Data:

According to ISO4064 (GB/T778.1-1996) Standard

Size		Class	Qs	Qp	Qt	Qmin	Min reading	Max reading
DN(mm)	Inch		Overload flow	Nominal flow	Transitional flow	Min flow		
		m ³ /h		L/h		m ³		
15	1/2"	A	3	1.5	150	60	0.0001	99999
		B			120	30		
		C			22.5	15		
20	3/4"	A	5	2.5	250	100	0.0001	99999
		B			200	50		
		C			37.5	25		
25	1"	A	7	3.5	350	140	0.0001	99999
		B			280	70		
32	1 1/4"	A	12	6	600	240	0.0001	99999
		B			480	120		
40	1 1/2"	A	20	10	1000	400	0.001	99999
		B			800	200		
50	2"	A	30	15	1500	600	0.001	99999
		B			1200	300		

INDICATING ERROR

At low zone is ±5% from minimum flow rate (qmin) to transitional flow rate (qt) exclusive boundary
 At high zone is ±2% from transitional flow rate (qt) to overload flow rate (qs)

Model: LXSG-15E-50E

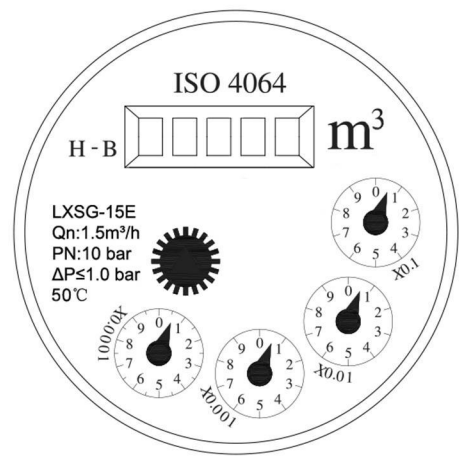
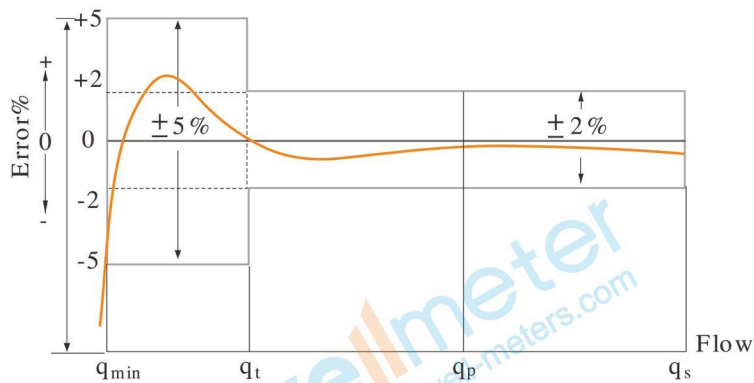

Head Loss Curve:

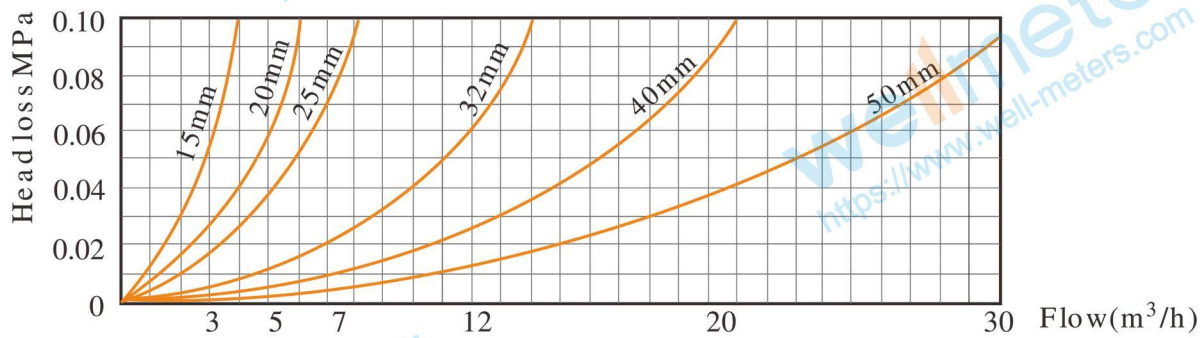

Dimensions and Weight:

Meter size Dia DN (mm)	Length mm	Width mm	Height mm	Connecting Thread D	Weight Kg
15	165	99	104	G 3/4B	1.5
20	190	99	106	G 1B	1.7
25	225	104	120	G1 1/4B	2.4
32	230	104	120	G1 1/2B	2.7
40	245	125	155	G 2B	4.5
50	300	125	155	G2 1/2 B	7.2
	280	165	175	FLANGE CONNECTING CONFORM TO GB4216.4 D=165 D1=125	14

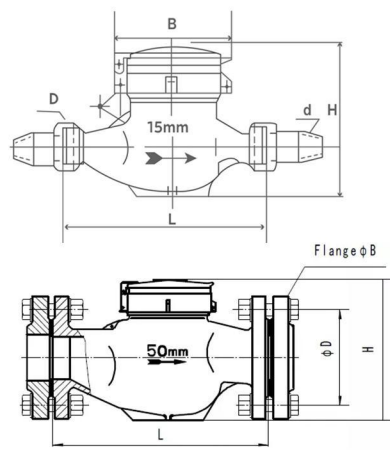

WORKING CONDITION:

- Water temperature: ≤50°C for cold water meter
- Water temperature: ≤90°C for hot water meter
- Working pressure: ≤1.6Mpa