

Model: LXC-15G-40G

Ultrasonic Water Meter

Feature:

- Communication interface options:
(1) M-BUS (2) RS-485 (3) Pulse output (4) LoRa
(5) LoRaWAN (6) NB-IoT
- Size: DN15 to DN40mm, (1/2" – 1 1/2")
- Accuracy: R400 / R250
- Frequency: LoRa/ LoRaWAN 865MHz, 902MHz, 868MHz, 915MHz and Others



Main Technical Data:

Item	Parameter
Meter Type	Ultrasonic Water Meter
Nominal Diameter (mm)	DN15~DN40
Q3/Q1	DN15-DN25 R400,R250; DN32-DN40 R250
Measured medium	Water
Accuracy class	Class 2
Water pressure class	1.6MAP (16 bar)
Pressure-loss class	DN15/DN20:Δp40 DN25/DN32/DN40:Δp63
Temperature class	T50
Installation position	H/V
The installation sensitivity	U0/D0
Electromagnetic class	E1
Environmental class	B
Key-press	Touch control technology
Types of Indicating device	LCD:9-digits, 0~99999.9999m ³
Menu Contents	Instantaneous flow (m ³ /h), cumulative flow (m ³), screen detection, table address, cumulative working time (h), date (year/month/day), caliber, software version
Communication Interface	M-BUS, RS-485, LoRa, LoRaWAN, Pulse output, NB-IoT
Power Source	Lithium battery ER26500(replaceable)
Battery Voltage &Capacity	3.6V , 8500mAh
Life span	10 years.
IP code	IP68
Storage Temperature	-25°C~+55°C
Cable length	1.0 m

Model: LXC-15G-40G

Drawing:

Flow Rate:

Parameter	Unit	Data Value				
Nominal Diameter		DN15	DN20	DN25	DN32	DN40
Start flow rate		0.002	0.002	0.003	0.005	0.005
Qmin(Q1)		0.00625	0.01	0.01575	0.04	0.064
QTransitional(Q2)	m ³ /h	0.01	0.016	0.0252	0.064	0.1024
Qn/permanent(Q3)		2.5	4	6.3	10	16
Qoverload(Q4)		3.125	5	7.87	12.5	20
Range		400			250	
Temperature		T50				
Battery life	Year	>10				

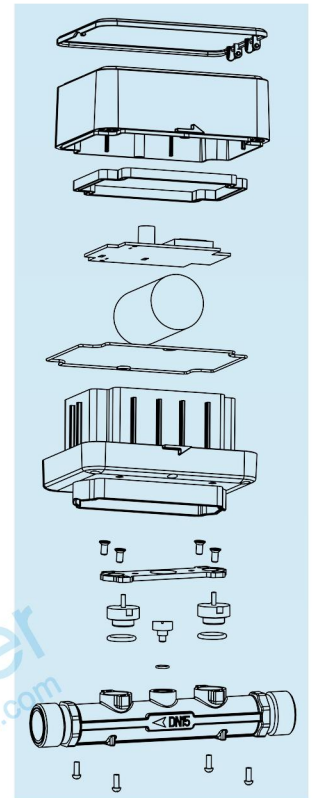

Error Curve:

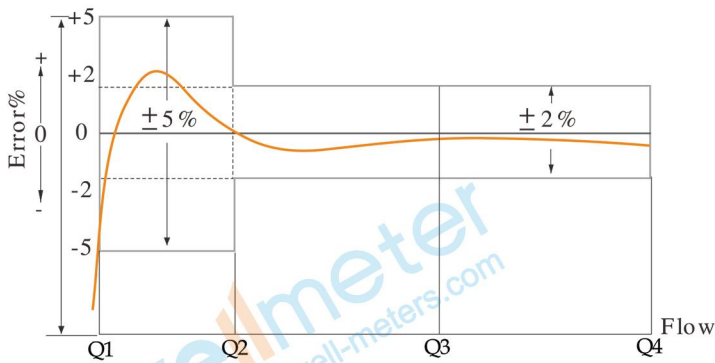

Head Loss Curve:

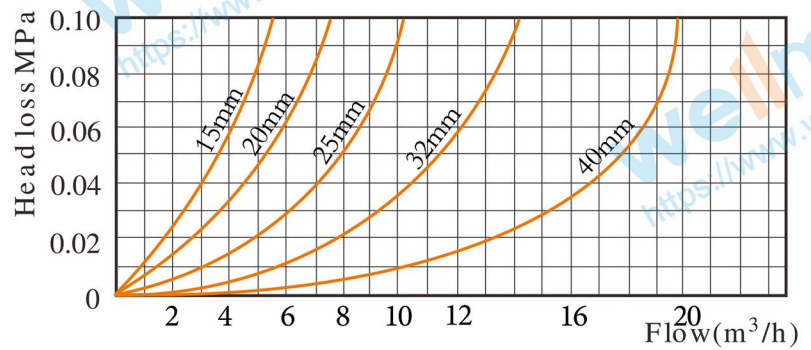

Dimensions:

Nominal Diameter (mm)	DN15	DN20	DN25	DN32	DN40
Thread	G3/4B	G1B	G1 1/4B	G1 1/2B	G2B
L(mm)	165	195	225	180	200
H(mm)	85	90	95	115	125
W(mm)	85	85	85	85	85

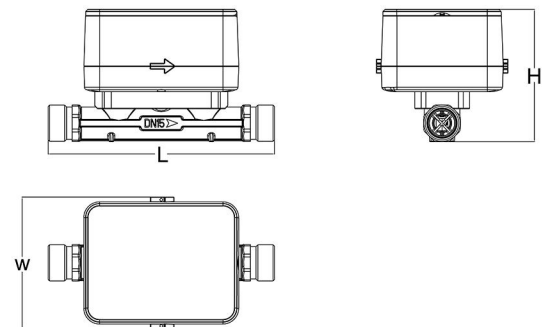

WORKING CONDITION:

Water temperature: ≤50°C for cold water meter

Water pressure: ≤16 Bar

wellmeter

Ningbo Well Energy Technology Co.,Ltd

<https://www.well-meters.com>

sales@well-meters.com

+86-574-63702808